

Keep this
manual onboard!



User Manual

For Hydraulic Retract Thruster Models
SRHP 650 Series



DOCUMENT ID: 7792

REVISION: 3

DATE: 2025

LANGUAGE: EN

**U
M**

Contents

Warnings and Safety	2
User Manual	
General Operation Consideration and Precaution Guidelines	3
User operation	4
Proportional control	4
Proportional control panel	5
Maintenance, vessel in water	6
Maintenance, vessel out of water	7
Basic troubleshooting	8
Online Troubleshooting and Fault Codes	8
Manually retracting the thruster	9
Maintenance checklist	10
Sleipner Group Waste Disposal and Recycling Guide	10
Service and Support	11
Product Spare Parts and Additional Resources	11
Warranty Statement	11

Warnings and Safety

MC_0800

It is essential to follow all instructions within this document to avoid potential personal injury, death, or damage to existing products in the vessel, the vessel's hull integrity, and including this product during installation or operation. Failure to follow instructions within this document will render all warranties given by Sleipner Motor as VOID.

Warnings and situations requiring extra caution are outlined in the documentation. Take extra consideration when warnings are outlined.



WARNING

Indicate a potentially hazardous situation that, if not avoided, could result in death or severe injury.



CAUTION

Indicates a potentially hazardous situation that could result in minor or moderate injury or critical damage to vessel integrity if not avoided.

MC_0020

For the operation of Sleipner thrusters systems:

MC_0418

- When not in use or when leaving the boat, turn the control device off.
- When leaving the boat, always turn off the main power switch for the thruster.
- Never run the thruster while out of water.
- Stop running the thruster and turn it off if the thruster stops giving thrust while running. Running the thruster for more than a few seconds without resistance from the propeller can cause severe damage to the thruster drive components.
- The thruster will not run if two conflicting directions are input in two control panels simultaneously.
- If you notice any faults with the thruster, switch it off to avoid further damage.
- The purpose of the thruster is to manoeuvre or dock the vessel. Forward or reverse speed must not exceed 4 knots when operated.



WARNING

Never use thrusters close to objects, persons, or animals in the water. The thruster will draw objects into the tunnel, as well as the rotating propellers. Contact with the rotating propellers will cause severe injuries and damage to the thruster.

Turn off the main power switch before touching any part of the thruster. An incidental start while touching moving parts can cause serious injuries.

Always plan on how to avoid damage to persons or other objects if the thruster stops giving thrust for while manoeuvring.

For the operation of hydraulic motor thrusters

MC_0421

- If the performance of the thruster is reduced check the hydraulic system or check the tunnel for marine growth.



WARNING

Accidental activation of the retract mechanism can cause serious injury due to the high-pressure force used for closing the hatch. IF operating the hatch during any work/ maintenance around or inside the retract hatch, USE CAUTION.



MC_0627

! Please refer to the graphic for special considerations relating to your model !

The following is an operation guide to ALL Sleipner control products. Ensure to familiarise yourself with the functionality and operation of your specific control device.



WARNING

Take time to practice operation in open water to become familiar with the thruster and to avoid damages to your boat or people.

General operation

1. Turn on the main power switch for the bow thruster. **(NB: Always turn off the main power switch when not on-board.)**
2. Turn on the control panel by pushing the/ both "ON" button(s) on the original Sleipner panel simultaneously.
Turn off the control panel by pushing the "OFF" button
3. To turn the bow/ stern in the desired direction:

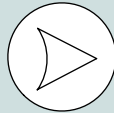

Button control panels

For button control, push the button in the corresponding direction you wish the bow/ stern to move.

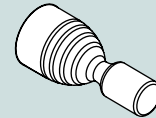

Joystick control panels

For joystick control, move the joystick in the direction you wish the bow/ stern to move.

(NB: If equipped for proportional control move the joystick equivalent to the amount of thrust you intend to receive.)

For other controls like foot switches or toggle-switches please refer to that products user manual for detailed operational use.

Hold functionality

If equipped with 'hold' functionality push the button in the corresponding direction you wish the thrusters to engage a holding pattern:

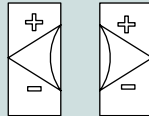

Hold Button

+ or -

Will increase or decrease the holding force output of the thrusters

Operating a combined bow and stern thruster

The combination of a bow and stern thruster offers total manoeuvrability to move the bow and the stern separately from each other or in unison. This enables the boat to move sideways in both directions or turn the boat around a 360° axis while staying stationary.

Remote controls



CAUTION

The remote control design reflects the vessel for orientation guidance. Be aware of the remote control orientation during operation.

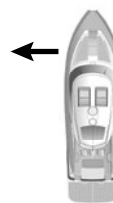
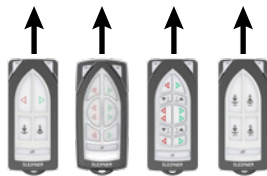

Remote control orientated with the vessel

Drift

Depending on the sideways speed of the bow/ stern, you must disengage the control device shortly before the vessel is in the desired position.

(NB: Be aware the boat will continue to move after disengaging the thruster control.)



CAUTION

At any significant cruising speed (+1-2 kn) the side thruster will have little effect to steer the vessel.

Proportional Control

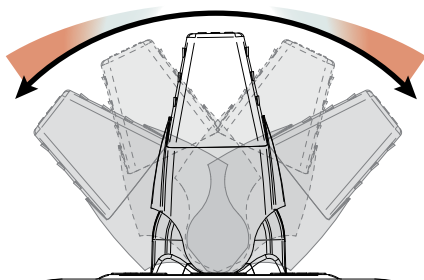

Variable thrust power for proportional thrusters is dependent on the extent of the joystick/ throttle.

For minimal thrust slightly move the joystick/ throttle in one direction.

For maximum thrust move the joystick/ throttle to its end point.

Proportional Control Panel

Activating the bow thruster

Using your control device/ panel press the button or move the joystick in the direction you intend to turn the boat. Ensure to use the control device/ panel designated for the bow thruster.

*Control panel example

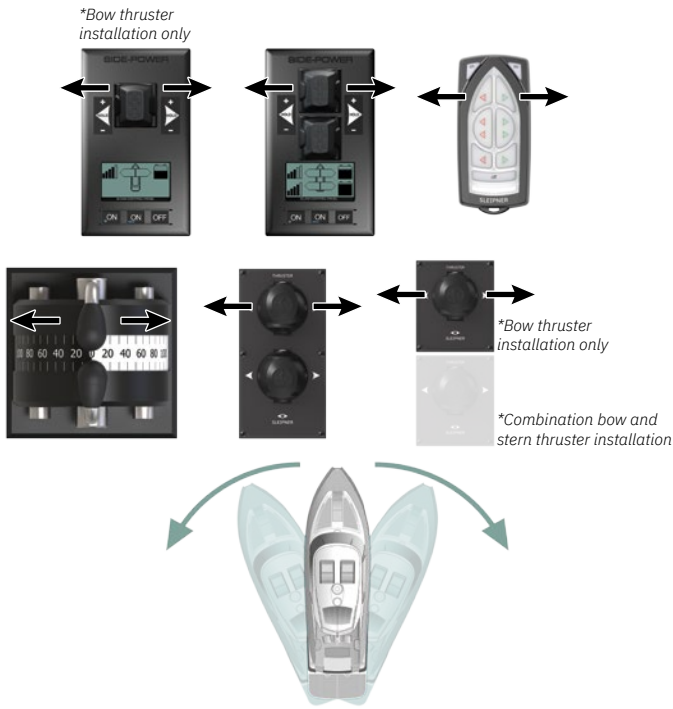

Activating the stern thruster

Using your control device/ panel press the button or move the joystick in the direction you intend to turn the boat. Ensure to use the control device/ panel designated for the stern thruster.

*Control panel example

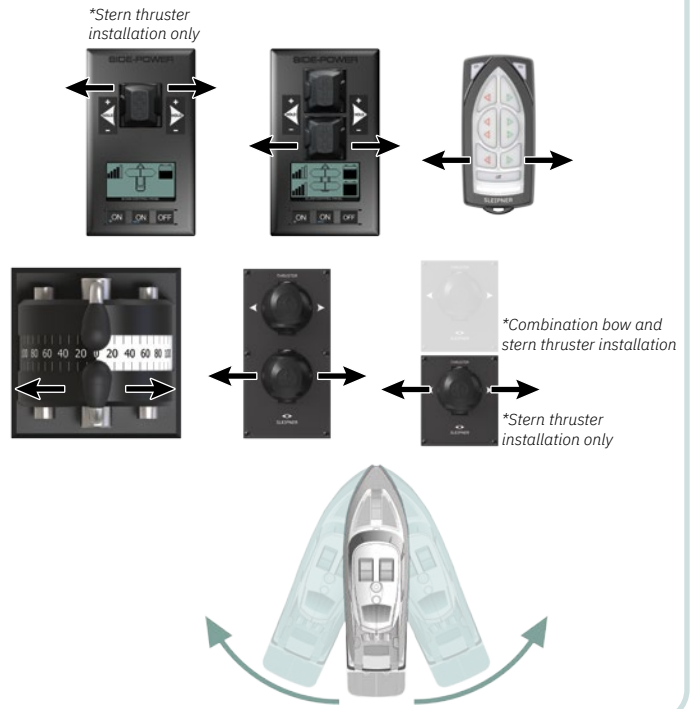

Activating full sidwards maneuverer

Using your control device/ panel press both buttons or move the joysticks in the same direction you intend to move the boat. Requires both a bow and stern thruster to perform.

*Control panel example

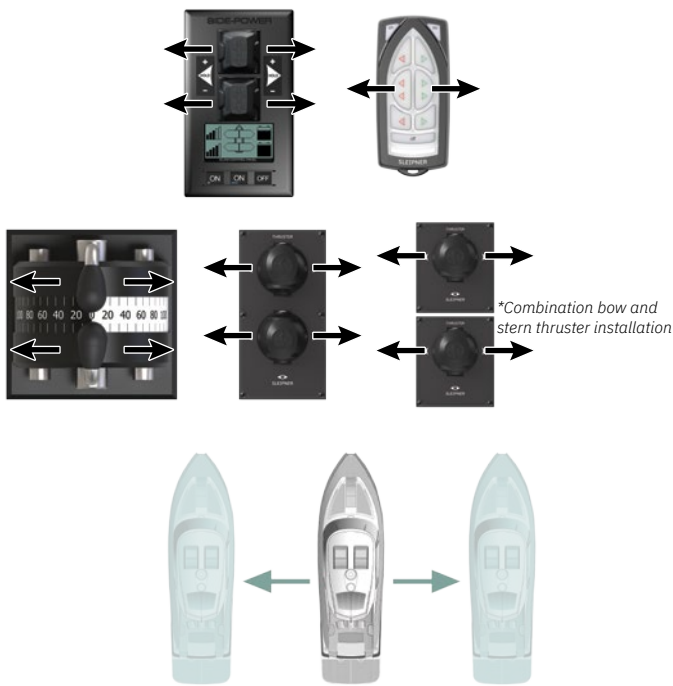

Activating stationary spin to rotate the boat on its axis

Using your control device/ panel press both buttons or move the joysticks in opposing directions. Requires both a bow and stern thruster to perform.

*Control panel example

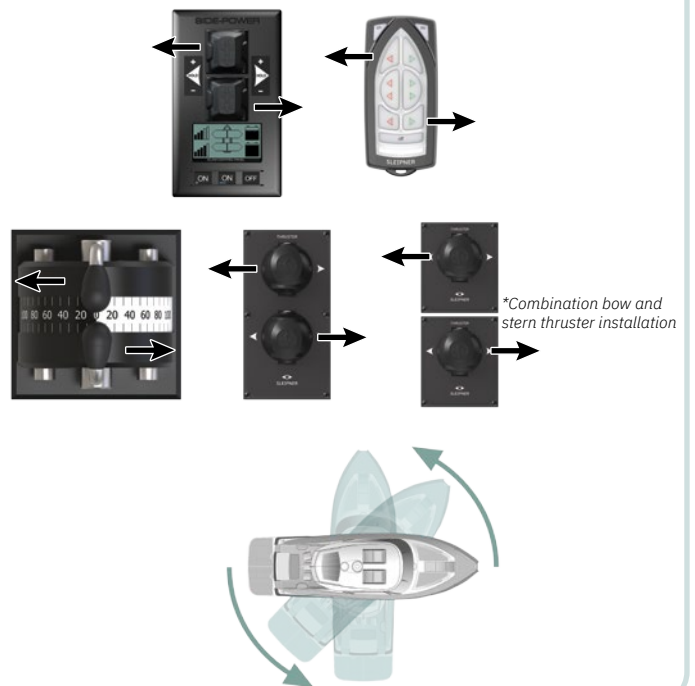

For additional information on your control panel or device refer to your control devices user manual

As a part of the seasonal service of your Thruster before every season, always check that:

- All electrical connections are clean and fastened firmly.
- Your batteries are in good condition.
- There is no leakage from the hydraulic hoses or fittings to the motor.
- The area around the thruster inside the boat is clean and dry.
- There are no signs of water/oil leaks from the following positions:
 - 1: Horizontal shafts, both sides
 - 2: Around the four bolts holding the motor bracket to the thruster housing.
 - 3: The joint between the motor bracket and the thruster housing.
 - 4: The joint between the actuator bracket and thruster housing.
 - 5: The joint between the lock arm bracket and the thruster housing.
 - 6: The joint between the thruster support flange and the thruster housing, and their retaining bolts.
 - 7: The oil filler plug on the motor bracket.

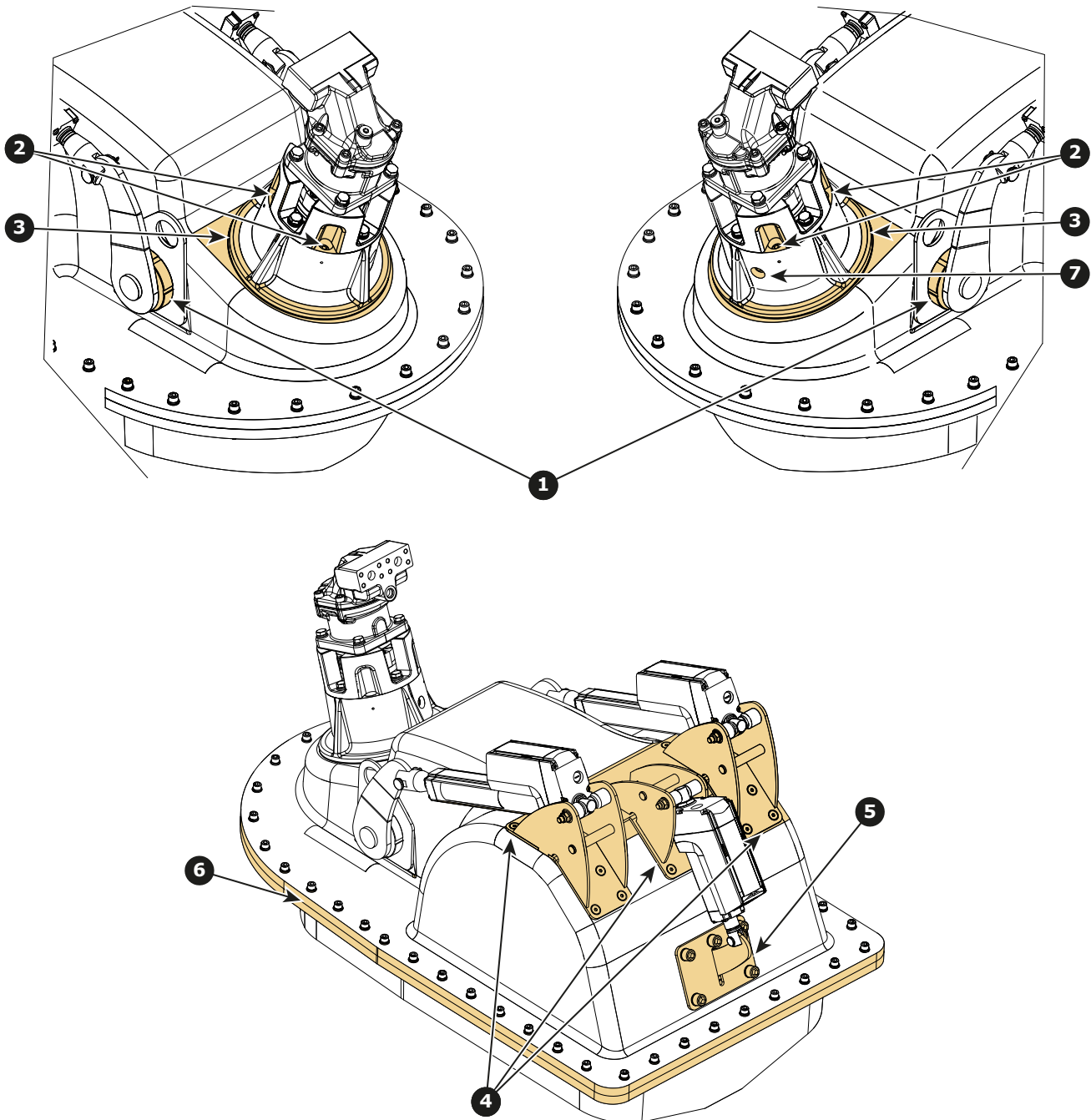

MG_0777

As a part of the seasonal service of your Thruster before every season, always check:

- The propeller and tunnel for damage.
- The propeller is fastened securely to the propeller shaft.
- The thruster tunnel and gear leg is clean and free from marine growth.
- The drive shaft for excessive movement.
- The dog clutch for excessive wear. **(Item 1)**.
- The twist rings **(Item 2)** for cracks or other damage.
- Change all the anodes **(Item 3)** before every season, or when half the anode has eroded (13 pcs of anodes). Always use thread lock on the screws to prevent it from coming loose.
- The hatch is properly secured to the thruster.
- There is no movement between the hatch and the hull in closed position.
- Apply anti fouling on the the propellers gear leg and inside the truster housing casing before every season to keep it clean from sea growth. **NB: Never apply anti fouling on the anode, propellers shaft or to rubber materials (sealing rings/boots). Ensure that the anti fouling does not enter the space between the propellers and the gear leg.)**

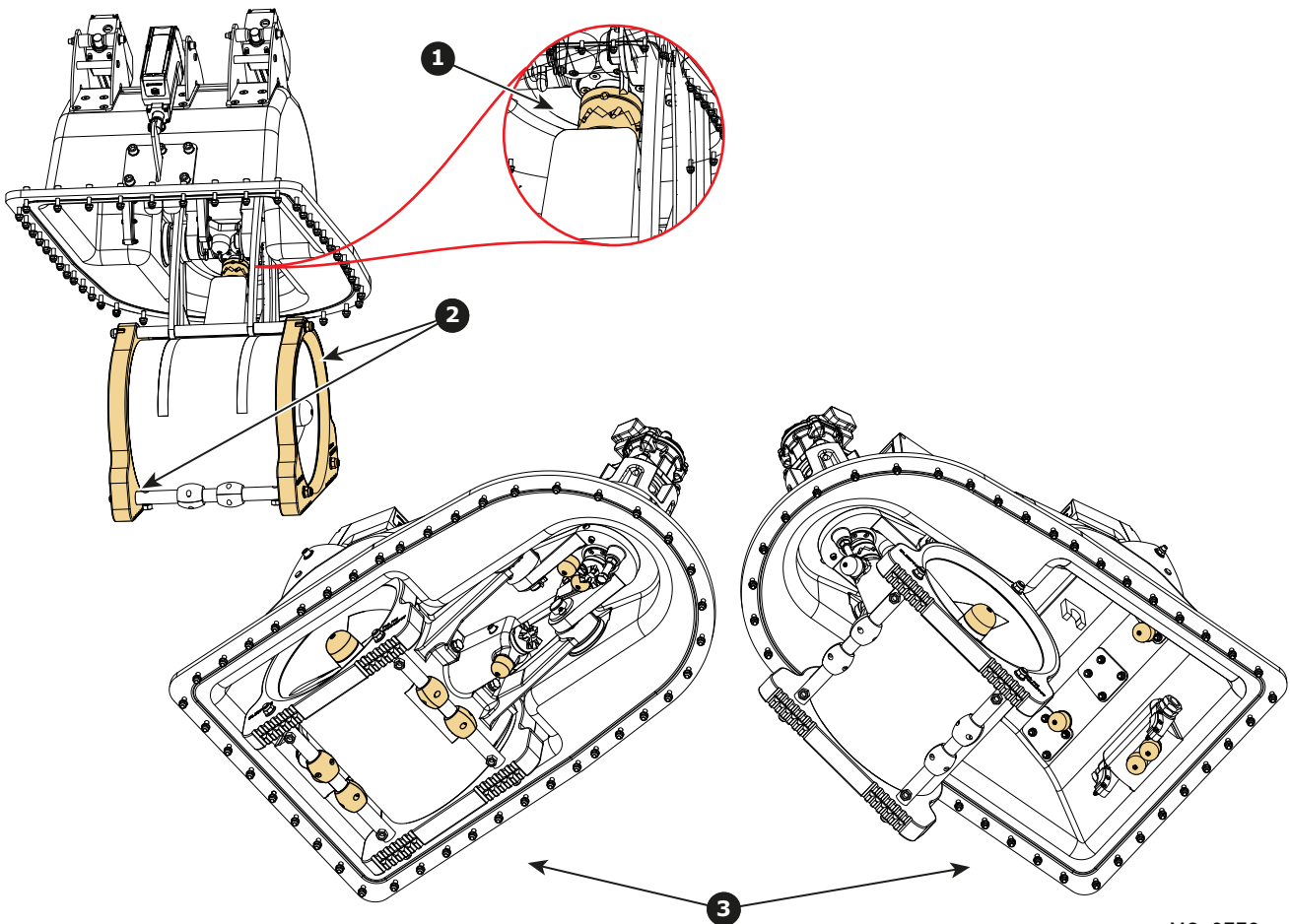

MG_0779

Always check the error code on the control panel before seeking assistance from the website help desk or from your Sleipner dealer/distributor. The error code is basic information for further action.

If you are unable to understand what to check, you must consult a Sleipner distributor.

Troubleshooting matrix	
Situation	Action
Thruster is not operating or malfunction	<p>Note the error code on the thruster control panel. Refer to the alarm and error code topics in this manual for identifying the problem, and possible solutions. Contact a Sleipner distributor or service department for further support and assistance.</p> <hr/> <p>In the thruster compartment, check if the hydraulic motor is running when operating the thruster. (Operate the control panel from the bridge while a person observes the thruster from the thruster compartment).</p>

Fault Code Navigator

Scan the QR code below to access Sleipner’s Fault Code Navigator. Fault codes can be entered in the Fault Code Navigator to receive fault description and guidance on resolving the issue.

A complete list of fault codes and troubleshooting tips can also be downloaded.



www.sleipnergroun.com/support/fault-code-navigator

In the event that the thruster has a malfunction, and is locked in the outer position, there is a possibility to retract the thruster manually.

Follow the procedure described below to solve this situation.

Note: If possible, try to find the root cause of the situation, before starting the manual retract process.

- 1: Remove the plastic covers from the hatch actuators (**Item 1**), using a suitable screwdriver. When removed, a 6mm hexagon pin is visible.
- 2: Turn the hexagon pin manually counterclockwise to close the hatch, using a 6mm socket wrench tool. (Use either a hand tool or a drill).

Each retract actuator (Item 1) must be turned alternately until the actuators are completely in their outer positions, and the hatch is closed.

- 3: The hatch is closed when the actuators are in the outer position, or when an increased torque is required to turn the hexagon pin.
- 4: Remove the plastic cap from the thruster lock actuator (**Item 2**).
- 5: Lock the hatch in the closed position by turning the 6mm hexagon pin counterclockwise until the actuator has moved 40-45mm from open position. (Or until an increased torque is observed when turning the hexagon pin).

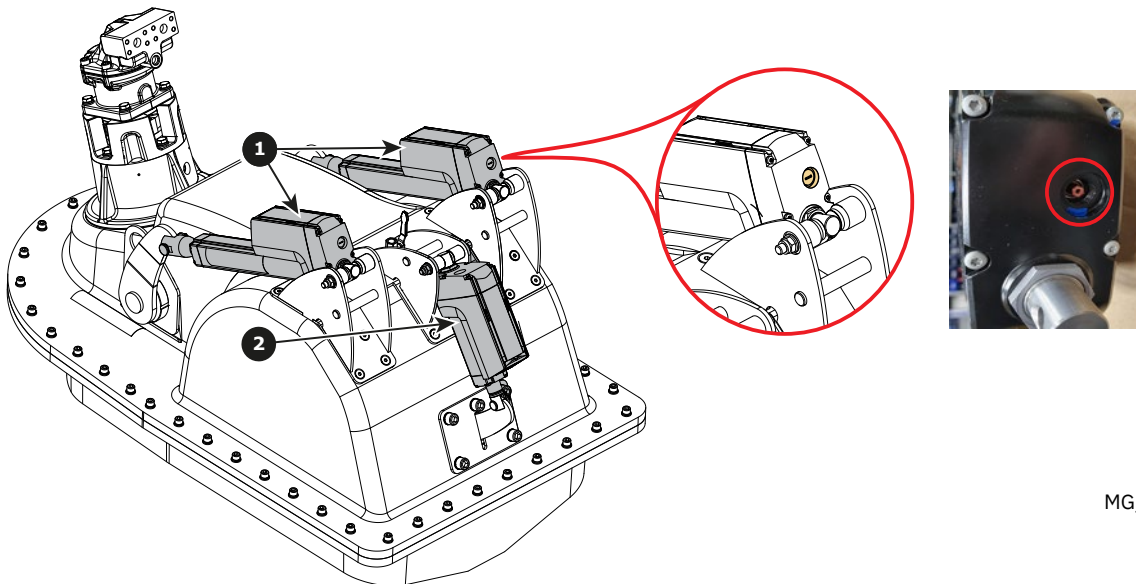

MG_0787

Maintenance items	Date of execution											
Vessel in water checkpoints												
Vessel out of water checkpoints												
Vessel in water checkpoints												
Vessel out of water checkpoints												
Vessel in water checkpoints												
Vessel out of water checkpoints												
Vessel in water checkpoints												
Vessel out of water checkpoints												

Sleipner Group Waste Disposal and Recycling Guide

Introduction:

At Sleipner Group, we prioritize sustainability and encourage the repair and re-manufacturing of products to extend their life cycles. If disposal is necessary, please follow these guidelines to recycle and manage waste responsibly, ensuring our efforts align with environmental protection efforts.

Electric Motors and Electronics:

- Disconnect from any power sources and dismantle them carefully.
- Recycle components through certified e-waste recycling centers that can adequately handle and recover electronic materials.
- Dispose of any non-recyclable electronic parts according to local environmental regulations.

Metals:

- Collect and sort metal parts for recycling as scrap metal.
- To increase recycling efficiency, ensure that metals are clean and free from non-metal attachments.

Plastics:

- Identify recyclable plastics based on local recycling guidelines.
- Remove any non-plastic components and clean them before recycling to improve the quality of the recycled material.

Hazardous Materials:

- Correctly identify any hazardous substances within components, such as batteries or capacitors etc.
- Follow local regulations for the safe disposal of hazardous materials to prevent pollution and protect environmental health.

General Disposal Instructions:

- Consult local recycling programs to determine the acceptability of various materials.
- Use authorized disposal services to ensure compliance with environmental standards.

Safe Disposal Practices:

- Adhere to local laws and regulations for waste management to minimize environmental impact and ensure community safety.

This guide is designed to help reduce our products’ environmental footprint through responsible end-of-life management. Please contact your local waste management supplier or our support team for more specific disposal information or further assistance.

Find your local professional dealer from our certified worldwide network for expert service and support. visit our website www.sleipnergrouper.com/support

Product spare parts and additional resources

For additional supporting documentation, we advise you to visit our website www.sleipnergrouper.com and find your Sleipner product.

Warranty statement

1. Sleipner Motor AS (The “Warrantor”) warrants that the equipment (parts, materials, and embedded software of products) manufactured by the Warrantor is free from defects in workmanship and materials for purpose for which the equipment is intended and under normal use and maintenance service (the “Warranty”).
2. This Warranty is in effect for two years (Leisure Use) or one year (Commercial and other Non-leisure Use) from the date of delivery/purchase by the end user, with the following exceptions:
 - (a) For demonstration vessels, or vessels kept on the water, the dealer is considered as the end user from 6 months after their launch of the vessel;
 - (b) The warranty period starts no later than 18 months after the first launch of the vessel.
 Please note that the boat manufacturer and dealer must pay particular attention to correct maintenance and service both by the products manuals as well as general good practice for the location the boat is kept in the period the boat is in their care. In cases where the 6 and 18 months grace periods for boat builders and dealers are passed, it is possible to obtain a full warranty upon inspection and approval of the warrantor or such representative.
3. Certain parts, classified as wearable or service parts, are not covered by the warranty. A failure to follow the required maintenance and service work as described in the product manual render all warranty on parts or components directly or indirectly affected by this void. Please also note that for some parts, time is also a factor separately from actual operational hours.
4. This Warranty is transferable and covers the equipment for the specified warranty period.
5. The warranty does not apply to defects or damages caused by faulty installation or hook-up, abuse or misuse of the equipment including exposure to excessive heat, salt or fresh water spray, or water immersion except for equipment specifically designed as waterproof.
6. In case the equipment seems to be defective, the warranty holder (the “Claimant”) must do the following to make a claim:
 - (a) Contact the dealer or service centre where the equipment was purchased and make the claim. Alternatively, the Claimant can make the claim to a dealer or service centre found at www.sleipnergrouper.com. The Claimant must present a detailed written statement of the nature and circumstances of the defect, to the best of the Claimant’s knowledge, including product identification and serial nbr., the date and place of purchase and the name and address of the installer. Proof of purchase date should be included with the claim, to verify that the warranty period has not expired;
 - (b) Make the equipment available for troubleshooting and repair, with direct and workable access, including dismantling of furnishings or similar, if any, either at the premises of the Warrantor or an authorised service representative approved by the Warrantor. Equipment can only be returned to the Warrantor or an authorised service representative for repair following a pre-approval by the Warrantor’s Help Desk and if so, with the Return Authorisation Number visible postage/shipping prepaid and at the expense of the Claimant.
7. Examination and handling of the warranty claim:
 - (a) If upon the Warrantor’s or authorised service Representative’s examination, the defect is determined to result from defective material or workmanship in the warranty period, the equipment will be repaired or replaced at the Warrantor’s option without charge, and returned to the Purchaser at the Warrantor’s expense. If, on the other hand, the claim is determined to result from circumstances such as described in section 4 above or a result of wear and tear exceeding that for which the equipment is intended (e.g. commercial use of equipment intended for leisure use), the costs for the troubleshooting and repair shall be borne by the Claimant;
 - (b) No refund of the purchase price will be granted to the Claimant, unless the Warrantor is unable to remedy the defect after having a reasonable number of opportunities to do so. In the event that attempts to remedy the defect have failed, the Claimant may claim a refund of the purchase price, provided that the Claimant submits a statement in writing from a professional boating equipment supplier that the installation instructions of the Installation and Operation Manual have been complied with and that the defect remains.
8. Warranty service shall be performed only by the Warrantor, or an authorised service representative, and any attempt to remedy the defect by anyone else shall render this warranty void.
9. No other warranty is given beyond those described above, implied or otherwise, including any implied warranty of merchantability, fitness for a particular purpose other than the purpose for which the equipment is intended, and any other obligations on the part of the Warrantor or its employees and representatives.
10. There shall be no responsibility or liability whatsoever on the part of the Warrantor or its employees and representatives based on this Warranty for injury to any person or persons, or damage to property, loss of income or profit, or any other incidental, consequential or resulting damage or cost claimed to have been incurred through the use or sale of the equipment, including any possible failure or malfunction of the equipment or damages arising from collision with other vessels or objects.
11. This warranty gives you specific legal rights, and you may also have other rights which vary from country to country.

Patents

At Sleipner we continually reinvest to develop and offer the latest technology in marine advancements. To see the many unique designs we have patented, visit our website www.sleipnergrouper.com/patents

© **Sleipner Motor AS**, All rights reserved

The information given in the document was right at the time it was published. However, Sleipner Motor AS cannot accept liability for any inaccuracies or omissions it may contain. Continuous product improvement may change the product specifications without notice. Therefore, Sleipner Motor AS cannot accept liability for any possible differences between product and document.

Learn more about our products at
www.sleipnergroun.com



SLEIPNER MOTOR AS

P.O. Box 519

N-1612 Fredrikstad

Norway

www.sleipnergroun.com

Made in Norway